

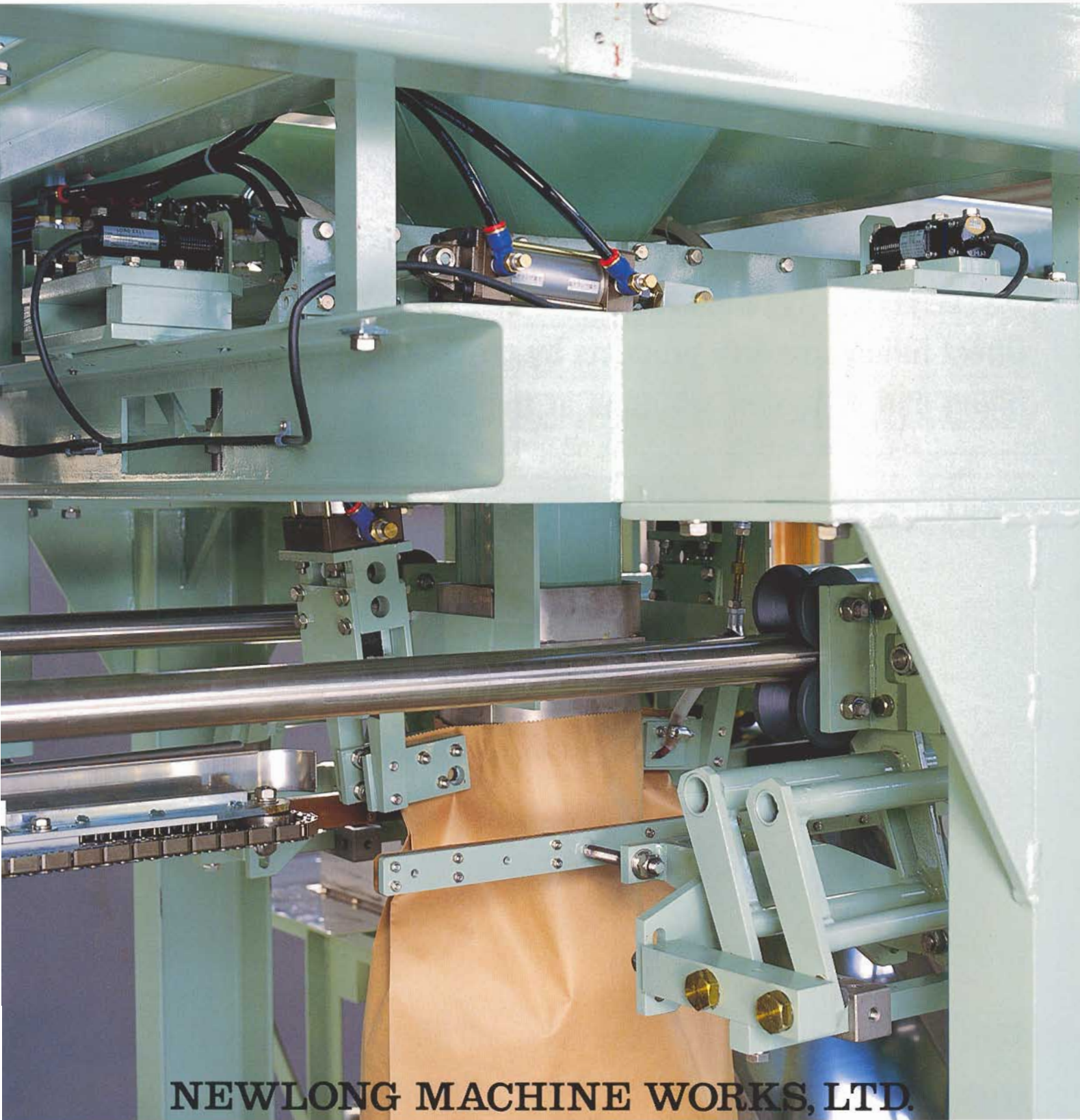

AUTOMATIC BAGGING MACHINE

3CM-3G/5G

Compactly Designed Gross Weighing and Bagging System



NEWLONG MACHINE WORKS, LTD.

GROSS-WEIGHING SYSTEM IDEAL FOR FULLY-

3CM-3G



WITH SCREW FEEDER

*Photo includes some option items.

Direct filling powdery products by gross-weighting system in which filling and weighing are done at the same time.

3CM-5G

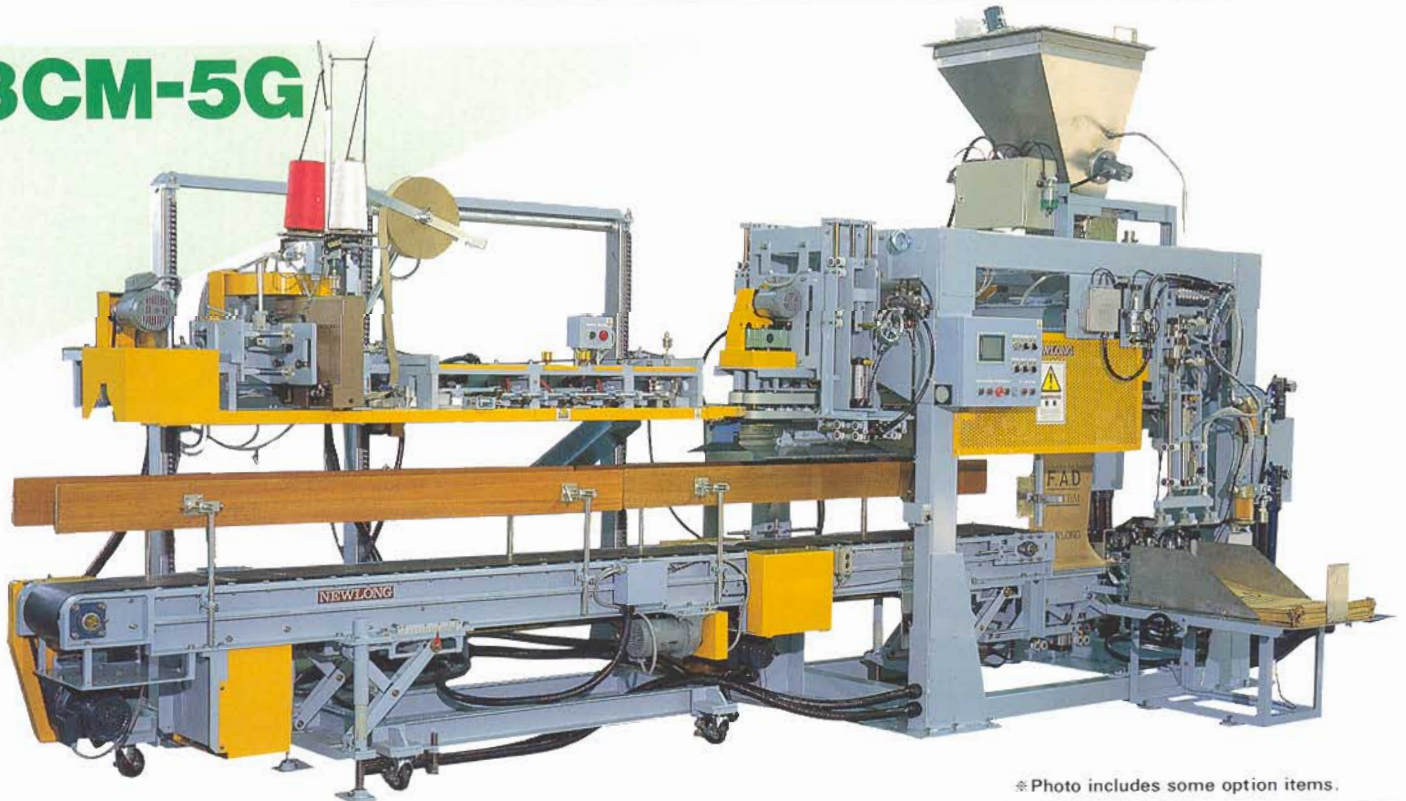

*Photo includes some option items.

3CM-5G is designed to place bags at fill-chute directly by swing type feeder, which is different from that of 3CM-3G.

AUTOMATIC BAGGING POWDERY PRODUCTS

3CM-3G-2

Equipped with air ridding device (the first filling & the secondary air ridding by vacuum air inhaler) for accelerating the machine speed of the Model 3CM-3G.

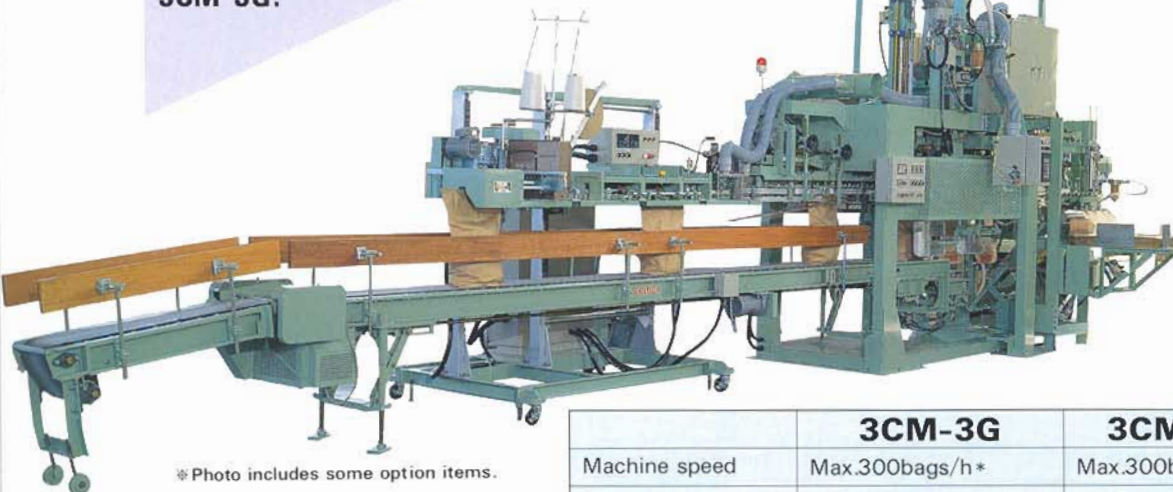

*Photo includes some option items.



VACUUM AIR INHALER

| | 3CM-3G | 3CM-3G-2 |
|-----------------|----------------------------------|----------------------------------|
| Machine speed | Max.300bags/h* | Max.300bags/h** |
| Accuracy | ±1/1000(20kg weighing) | ±1/1000(20kg weighing) |
| Paper bag size | BW380~500mm BL 650~850mm | BW380~500mm BL 650~850mm |
| Air consumption | 400Nℓ/min(5kg/cm ² G) | 600Nℓ/min(5kg/cm ² G) |
| Power required | Approx. 4.3KW*** | Approx. 4.5KW*** |
| Machine weight | Approx. 2.5t | Approx. 3.0t |

OPTION

- Bag Printer
- Date/Code Printer
- Dust Extractor
- Air Ridding Device on Main Conveyor
- Bag Top Former for Air Ridding

- * Depends on products and bag size.
- ** The machine speed of 3CM-3G-2 is faster than 3CM-3G, running on the same products and bag size.
- *** With Model A2-P2L(DS-6) bag closing machine.

● Specifications subject to change without notice.

3CM-5G-2

Equipped with air ridding device (the first filling & the secondary air ridding by vacuum air inhaler) for accelerating the machine speed of the Model 3CM-5G.



BAG TOP FORMER FOR AIR RIDDING (OPTION)

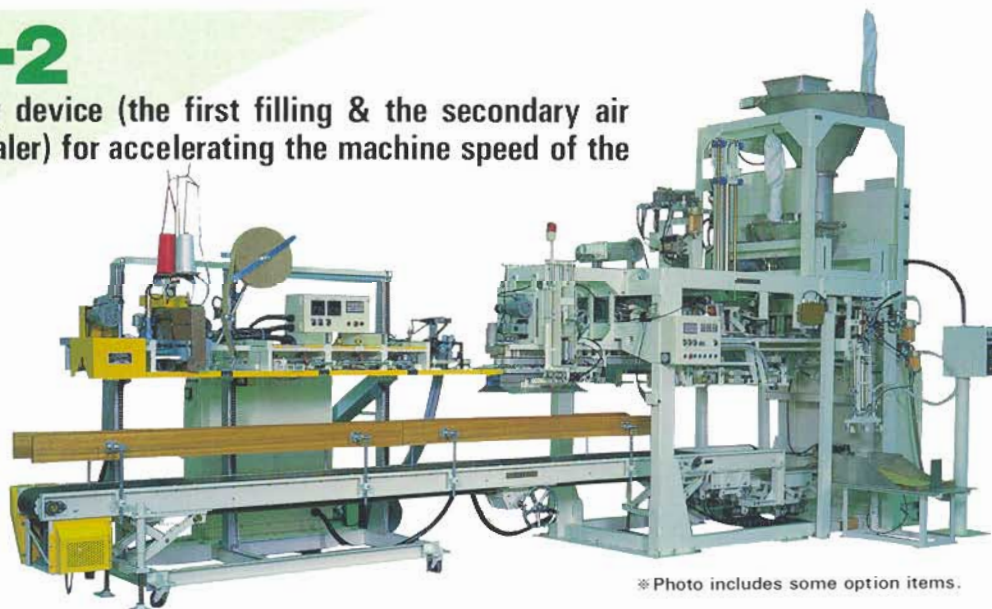

*Photo includes some option items.

| | 3CM-5G | 3CM-5G-2 |
|-----------------|----------------------------------|----------------------------------|
| Machine speed | Max.230bags/h* | Max.230bags/h** |
| Accuracy | ±1/1000(20kg weighing) | ±1/1000(20kg weighing) |
| Paper bag size | BW380~500mm BL 650~850mm | BW380~500mm BL 650~850mm |
| Air consumption | 300Nℓ/min(5kg/cm ² G) | 450Nℓ/min(5kg/cm ² G) |
| Power required | Approx. 3.2KW*** | Approx. 3.5KW*** |
| Machine weight | Approx. 2.5t | Approx. 3.0t |

OPTION

- Bag Printer
- Date/Code Printer
- Dust Extractor
- Air Ridding Device on Main Conveyor
- Bag Top Former for Air Ridding

- * Depends on products and bag size.
- ** The machine speed of 3CM-5G-2 is faster than 3CM-5G, running on the same products and bag size.
- *** With Model A2-P2L(DS-6) bag closing machine.

● Specifications subject to change without notice.

VARIETY CHOICE OF FEEDER DEPENDING ON PRODUCTS

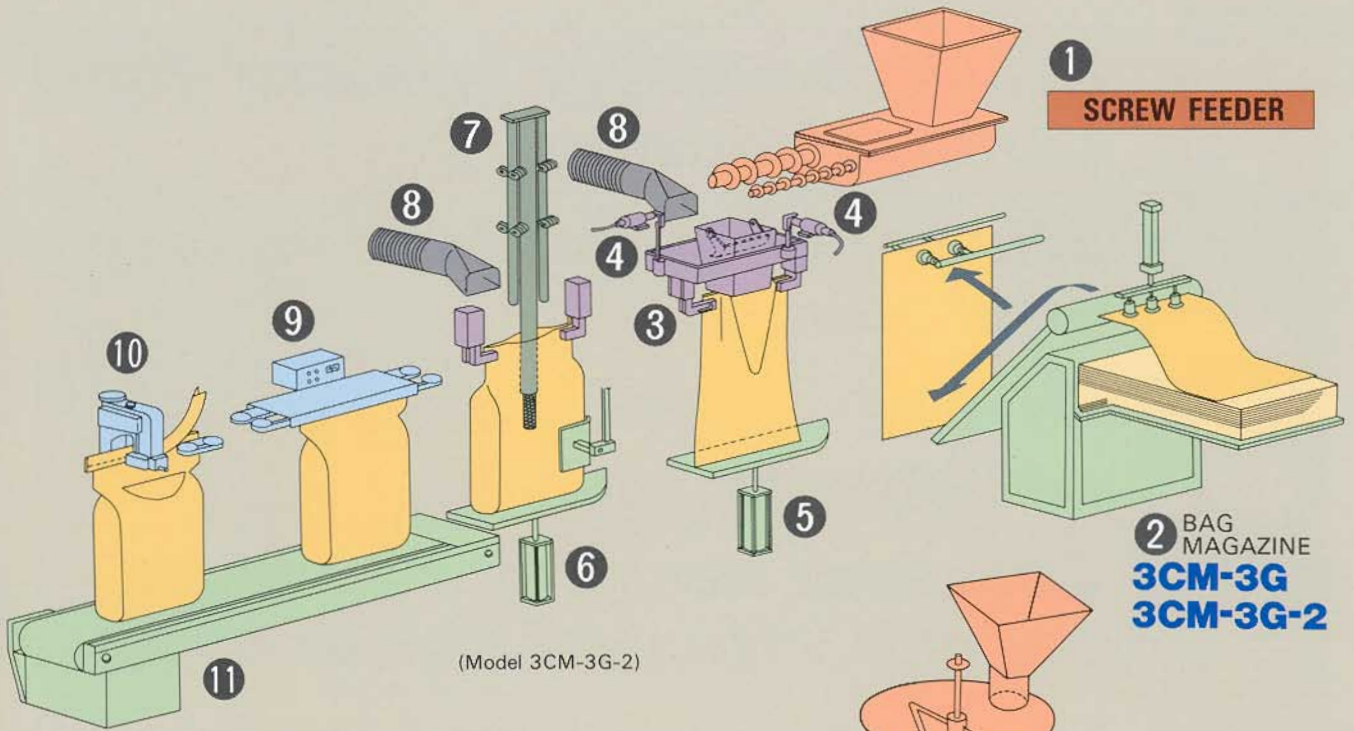

(Model 3CM-3G-2)

1
SCREW FEEDER

2 BAG
MAGAZINE
3CM-3G
3CM-3G-2

- ① PRODUCTS FEEDER
- ② BAG MAGAZINE
- ③ BAG OPENER & FILLER
- ④ LOAD-CELL
- ⑤ BAG BOTTOM TAPPER ON THE FIRST FILLING STATION
- ⑥ BAG BOTTOM TAPPER ON THE SECOND AIR RIDDING STATION
(only for Model 3CM-3G-2, 3CM-5G-2)
- ⑦ VACUUM AIR INHALER
(only for Model 3CM-3G-2, 3CM-5G-2)
- ⑧ DUST EXTRACTING PIPES
- ⑨ HEAT SEALER (or OVER TAPE SEALER)
- ⑩ BAG CLOSING MACHINE
- ⑪ MAIN CONVEYOR

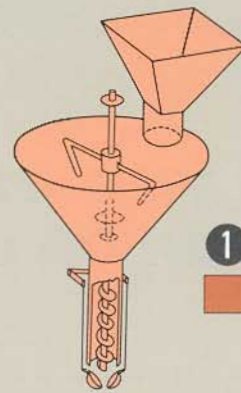

1
AUGAR

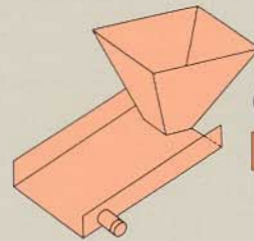

1
MAGNETIC FEEDER

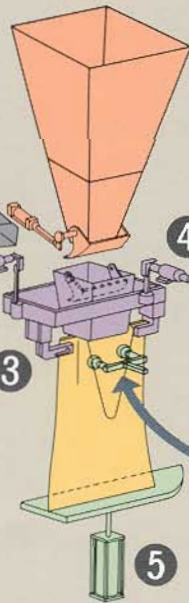

1
CUT-OFF GATE

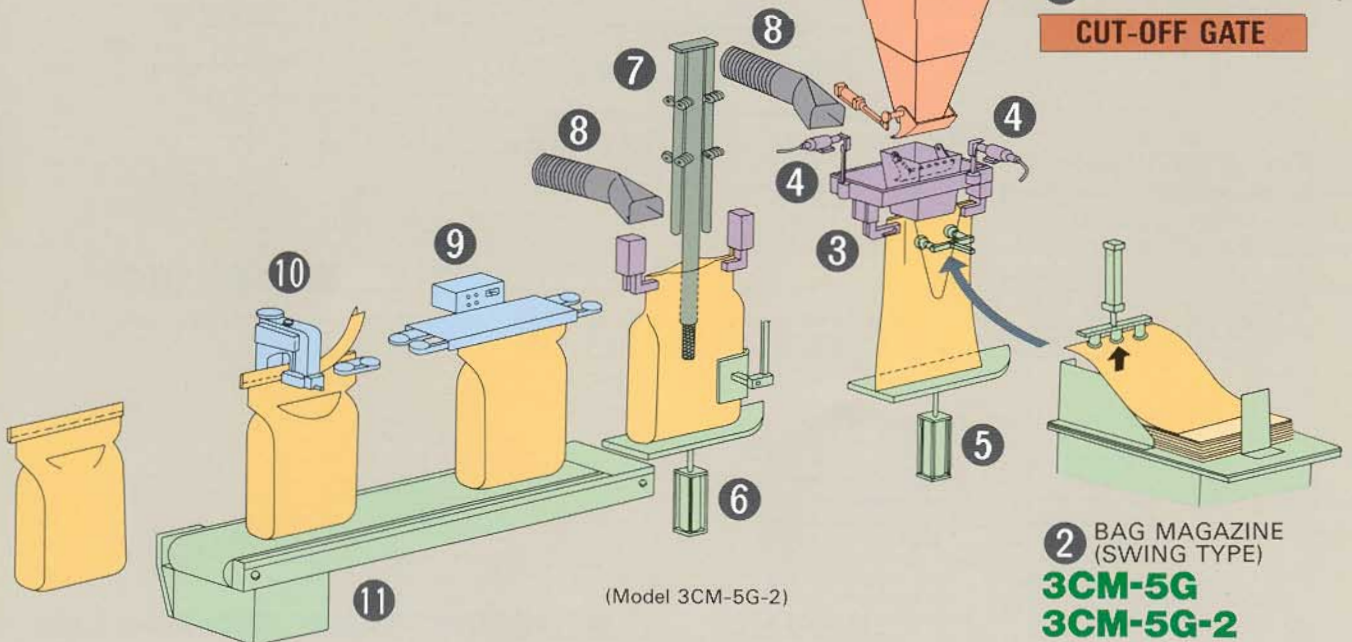

(Model 3CM-5G-2)

2 BAG MAGAZINE
(SWING TYPE)
3CM-5G
3CM-5G-2

- 1. Gross weighing system for compact design**
- 2. Wide application for a variety of products**
- 3. Direct filling drastically reduces weigh loss**
- 4. Compact design for economical and efficient use of space**
- 5. Type of feeder and weigher can be chosen to suit product**

Gross-weighing system

***Ideal for powdery products**
 Unlike net-weighing, products fill into a bag directly and are weighed, causing no sticking and no dispersing of the products.

***Compact, less space required**
 Compact design saves space and height for installation.

Weighing mechanism

System - Gross weighing
 Detection - By load-cell
 Weight - Digital display
 Auto dribble feed compensator,
 Auto zero adjust, Auto under weight compensator

Any kinds of open-mouth bag can be used

Paper, polyethylene, woven-cloth, or paper-cloth bag. Various bag size available.

Safety and interlock system

***Mis-clamped and mis-opened bag detector**
***Optional items**
 Detection of no bag on magazine, thread break detector, thread scanner, crepe-tape scanner, and detection of air-pressure drop

Feeder application

Feeder has a variety choice, depending on product.

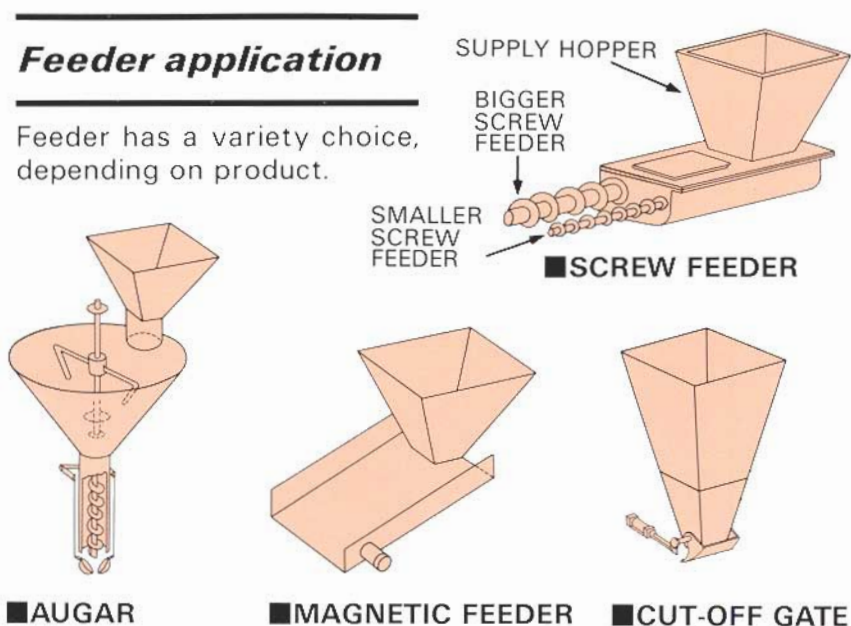

■AUGAR

■MAGNETIC FEEDER

■CUT-OFF GATE

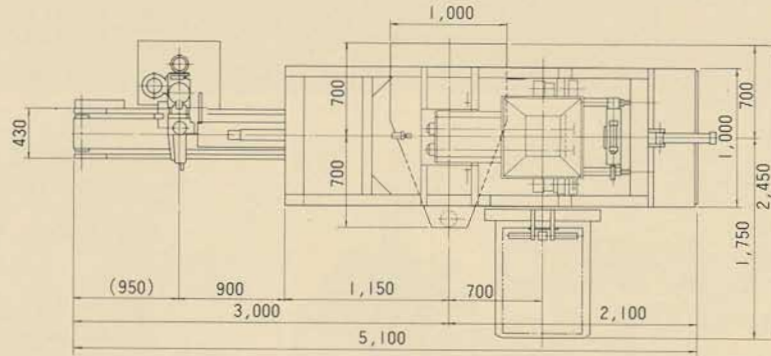

3CM-3G

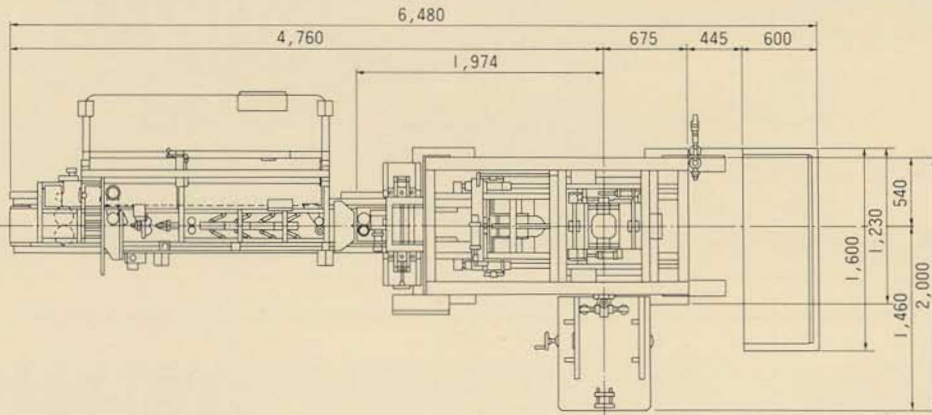
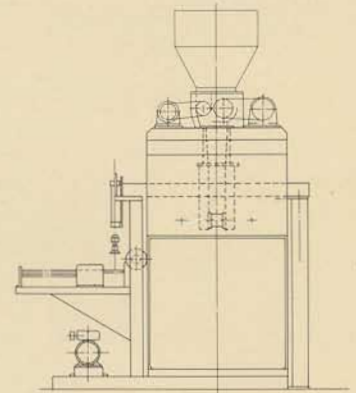
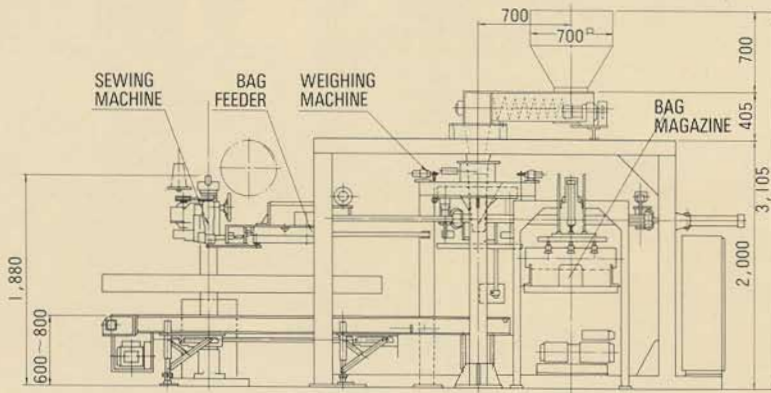

3CM-5G

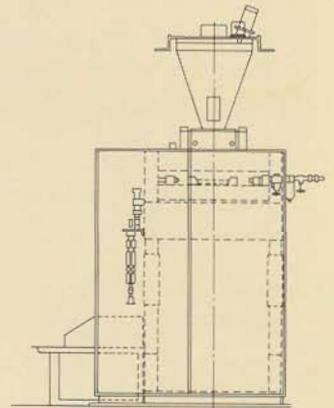
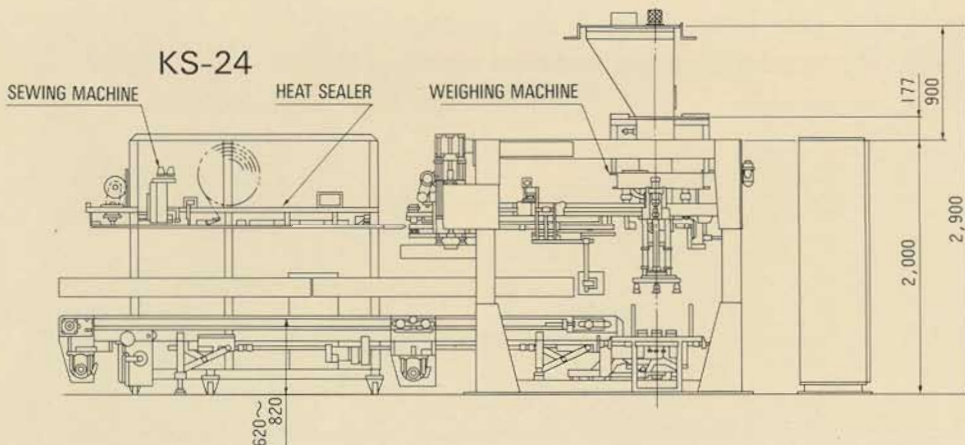

NEWLONG MACHINE WORKS, LTD.

HEAD OFFICE: 14-14, Matsugaya 1-Chome, Taito-ku, Tokyo 111-0036, Japan

Fax: (03)3843-0260 Tel: (03)3843-0269

OVERSEAS OFFICE: AMERICAN-NEWLONG, INC

NEWLONG DO BRASIL MAQUINAS INDUSTRIAS LTDA.

NEWLONG (HONG KONG) CO., LTD.

NEWLONG HOLLAND B.V.

NEWLONG MALAYSIA SDN. BHD.

NEWLONG MACHINE PHILIPPINES, INC.

NEWLONG SINGAPORE PTE. LTD.

NEWLONG TAIWAN MACHINE CO., LTD.

NEWLONG (THAILAND) LTD.

NEWLONG FZE, Dubai

NEWLONG LATIN AMERICA, INC. Miami

FAX: (1-317)786-5225

FAX: (55-11)276-9084

FAX: (852)2577-2876

FAX: (31-20)653-2416

FAX: (60-3)717-6000

FAX: (63-2)896-2234

FAX: (65)265-1994

FAX: (886-2)2522-1420

FAX: (66-2)391-5508

FAX: (971-4)838-688

FAX: (1-305)406-1039

TEL: (1-317)787-9421

TEL: (55-11)276-9744

TEL: (852)2576-3676

TEL: (31-20)653-2350

TEL: (60-3)718-8323

TEL: (63-2)896-1919

TEL: (65)265-0901

TEL: (886-2)2571-6524

TEL: (66-2)391-1171

TEL: (971-4)838-788

TEL: (1-305)406-1038

*Fax & telephone number starts with the country number-area code number written in the bracket, followed by the individual number. (the country number-area code)